

Set 810 S

Bedienungsanleitung
Instructions for use
Notice d'emploi
Istruzioni per l'uso
Instrucciones para el uso
Gebruiksaanwijzing
Bruksanvisning

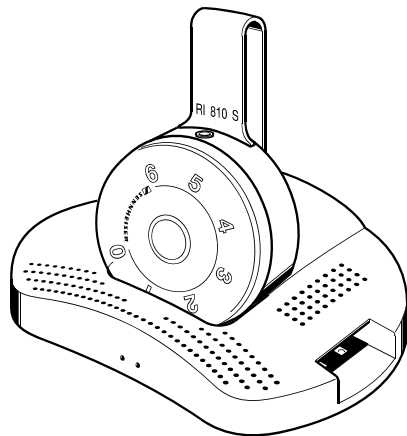

Set 810 S

The Set 810 S is an assistive listening system for your radio, TV, hi-fi system or similar sound sources at the volume you choose. The system allows you to move around freely without the constrictions of cables within the room where the transmitter is placed. The system uses invisible infrared light for sound transmission.

The RI 810 S is an infrared stereo receiver which features an audio socket for connecting a pair of headphones, induction accessories or hearing aids with audio input. The RI 810 S receives music and speech via cordless transmission from a TI 810 infrared stereo transmitter.

The EZT 1011 induction neck loop inductively transmits the audio signal from the receiver to hearing aids in T-position.

Contents

The Set 810 consists of the following components and accessories:

- Receiver RI 810 S
- Transmitter
(charging unit) TI 810
- Rechargeable battery BA 151
- Power supply NT 810
- Induction neck loop EZT 1011
- Microphone MKE 800 TV
(USA/UK only)
- Connecting cable for
headphone output
- Adapter for SCART socket
(except USA/Canada)
- Adapter for RCA sockets
(USA/Canada only)
- Instruction manual

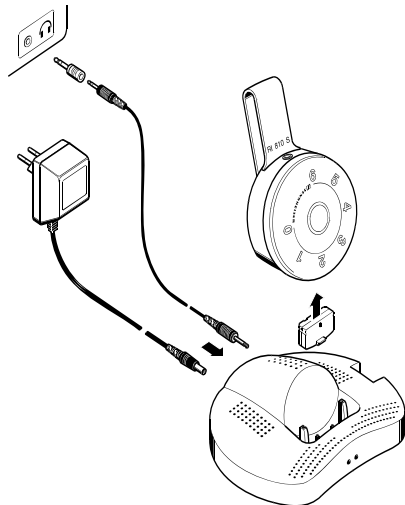
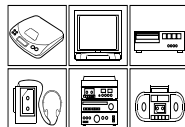

Connecting the transmitter (charging unit)

The rear of the transmitter is fitted with two audio inputs: A socket (LINE) for connection to the audio output or the headphone socket on your TV, and a microphone socket (MIC).

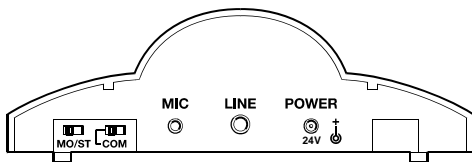

Plug in one end of the connecting cable to the audio output or the headphone socket on your TV, and the other end to the LINE socket on the transmitter.

If your TV set is fitted with a SCART socket, use the supplied adapter.

If your TV does not have a headphone or SCART socket, you can use an external microphone which is described in the section "Accessories".

Only use one of the two audio inputs on the transmitter (MIC or LINE).

Connect the power cable to the POWER socket on the transmitter. Plug the power supply into a household electrical outlet.

Pull the power supply unit out of the electrical outlet when the unit will not be used for extended periods of time.

Where to place the transmitter

Place the transmitter so that the infrared light beam is pointed directly at the receiver, i. e. there should be no obstacles in the light path between transmitter and receiver. Guide the cables backwards.

Avoid exposure to direct sunlight. Direct sunlight may interfere with the reception and may damage the transmitter.

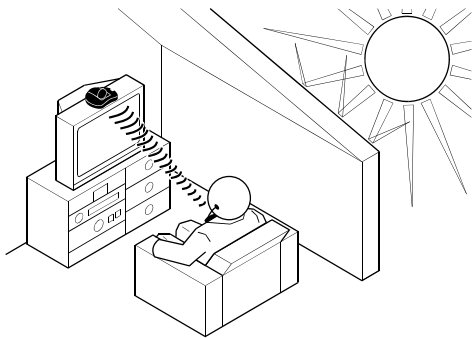

Using the receiver

The receiver is turned on automatically as soon as a 3.5 mm stereo jack plug is inserted into the socket at the top of the receiver.

Affix the receiver to the clothing by means of its integrated attachment clip. Make sure the receiver is positioned correctly, with the operating control facing the transmitter. **There must be a free line of sight between the transmitter and the receiver.**

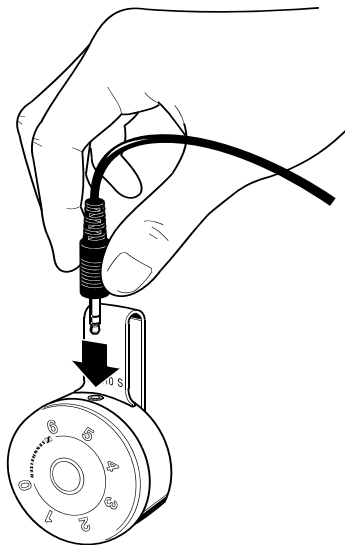

Using the induction neck loop

Put the EZT 1011 induction neck loop around your neck and insert its plug into the socket at the top of the receiver. Set your hearing aid to position "T".

Adjusting the volume

Adjust the receiver's volume with the operating control. Make sure your hand doesn't cover the operating control completely. This may prevent interference-free reception.

If you are not using the receiver, pull the 3.5 mm stereo jack plug out of the receiver's socket to avoid discharging the battery. The receiver is then turned off.



Turning the automatic compression system on

Use the COM switch (compression) at the rear of the transmitter to turn the automatic compression system on. This system reproduces soft passages louder and decreases loud sounds. Choose the setting that suits your listening preferences.

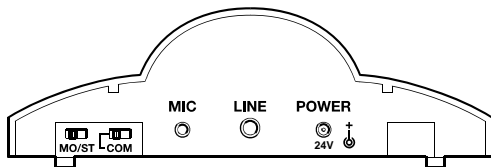

Use the MO/ST switch to choose between mono and stereo transmission. For mono TVs and when using the MKE 800 TV microphone, the switch must be set to mono (MO).

Charging the battery

Place the receiver into the transmitter's charging compartment, with the operating control at the front. Pull the 3.5 mm stereo plug out of the receiver to turn the receiver off. The left LED on the transmitter must light up.

Charge the battery for 24 hours before you use it for the first time. The normal charging time is 4-5 hours. A fully charged battery has an operating time of approx. 4 hours. When charging a spare battery in the small charging compartment at the right of the transmitter, charging time is 10-12 hours.

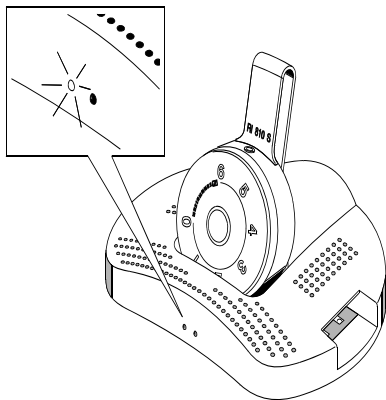

The transmitter automatically switches to trickle charging so that the battery cannot be overcharged. The receiver can remain in the charging compartment even when the battery has been fully charged.

A battery has a service life of 1-2 years and should be replaced if the operating time decreases.

Sennheiser batteries can be recycled. Please dispose of the batteries as special waste or return them to your specialist dealer. To protect the environment, only dispose of totally exhausted batteries which cannot be recharged.

Additional information

This system uses infrared light which is emitted by the transmitter and received by the receiver. Please note that infrared light emitted by other light sources may interfere with the useful signal of the Set 810 S.

If the light path between transmitter and receiver is obstructed by clothing such as scarves etc., the reception may also be disturbed.

Varnish or furniture polish may degrade the rubber feet of the transmitter. Place the transmitter on a nonslip pad to avoid potential staining of furniture.

Use a soft cloth for cleaning the units. Do not use abrasive cleaners.

According to today's scientific knowledge, the infrared light emitted by this unit is not harmful to humans or animals.

WARNING: Volume up? - No!

When people use headphones, they tend to choose a higher volume than with loudspeakers. However, if your hearing has deteriorated and you need to rely on an assistive listening system, please avoid listening at high volume levels for a long time. Please protect your hearing.

ATTENTION: Danger of short circuit!

Neither transmitter nor receiver must get wet or excessively moist, e.g. due to spilled liquids or use in damp rooms.

Accessories

Only use original Sennheiser spare parts and accessories.

ATTENTION: Components from other manufacturers (e.g. for power supply or battery) may cause damage to the unit and will invalidate the warranty.



The following accessories are available from your authorized dealer:

Rechargeable battery	BA 151
Charger	L 151-2
Additional receiver	RI 810 S
Transmitter	TI 810
External microphone	MKE 800 TV
Induction couplers	EZI 120
Dynamic headphones	HD 25 SP
HZL series connecting cable (for direct connection to hearing aids)	

BA 151 rechargeable battery

By using a spare battery, you can use the receiver for more than four hours of continuous operation. Always store the spare battery in the small charging compartment at the right of the transmitter. The right LED on the transmitter lights up green to show charging is taking place. When charging an battery in the small charging compartment, the charging time is 10-12 hours.

L 151-2 charger

Spare batteries can be charged via the L 151-2 charger.

RI 810 S additional receiver

One transmitter can transmit to several receivers. Additional RI 810 S receivers are available from your authorized dealer.

MKE 800 TV external microphone

If your TV doesn't have a headphone output, SCART or RCA socket, you can use your Set 810 S together with the MKE 800 TV microphone.

Fix the microphone to the loudspeaker of your TV by means of Velcro tape. Connect the microphone connector to the MIC socket on the transmitter and set the MO/ST switch to mono (MO).

HD 25 SP dynamic headphones

Closed dynamic headphones for connection to the RI 810 S.

Any dynamic headphones with a 3.5 mm stereo jack plug and a minimum impedance of 32 ohms can be connected to the RI 810 S receiver.

EZI 120 induction couplers

Induction couplers for inductive audio transmission to hearing aids.

If problems occur...

- Are all jack plugs connected correctly?
- Are the receiver and sound source turned on and is the volume of the receiver and sound source sufficient?
- Is the rechargeable battery inserted properly into the receiver?
- Have you charged the battery for at least 20 minutes?
- Are the transmitter's LEDs pointed at the receiver?
- Is the receiver's operating control pointed at the transmitter?
- Is there a free line of sight between transmitter and receiver?
- Should the problem persist, please contact your authorized dealer for assistance.



Never open the unit!

Additional information for hearing aid acousticians

Adjustments for hearing disabilities

Attention:

In order to ensure interference-free reception, only use the potentiometers shown below.

Turn the operating control fully to the left (0). Remove the operating control by carefully lifting it over the "guide notch" on the inside. Use the 4 potentiometers on the circuit board to individually adjust the max. volume and the bass response for the left and right headphone system.

Adjusting the max. volume:

Potentiometer turned fully to the left:
Potentiometer turned fully to the right:

Adjusting the bass response:

Potentiometer turned fully to the left:
Potentiometer turned fully to the right:

min.
max.

attenuation of 25 dB at 100 Hz
attenuation 0 dB

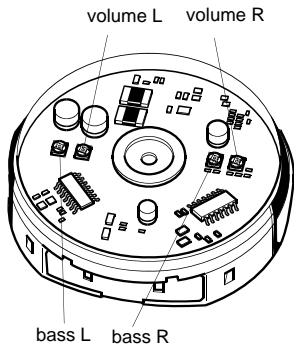

The adjustments can also be made when the receiver is being used.

When replacing the operating control, make sure the "projections" on the inside of the operating control point in the direction of the attachment clip.

After replacing the operating control, synchronize the operating control with the volume control by once turning it fully in both directions.

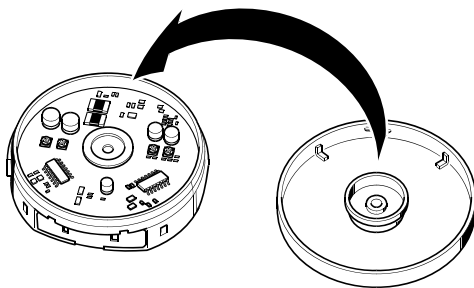

Specifications

System

Modulation	FM, stereo
Carrier frequencies	2.3 / 2.8 MHz
AF frequency response	40 Hz 15 kHz
S/N ratio	60 dB A rms

Transmitter

AF input voltage	50 mV 5 V
Audio input	3.5 mm jack, stereo/mono
Microphone socket	2.5 mm jack, mono
Charging time for battery	approx. 4 h
Charging time (spare battery)	approx. 10-12 h
Power supply	24 V DC via NT 810 mains unit
Weight	approx. 94 g (without battery)
Dimensions	diameter: 150 mm, height: 47 mm

Receiver

AF frequency response	40 Hz 15 kHz
S/N ratio	60 dB A rms
Power supply	2.4 V via BA 151 battery
Operating time	approx. 4 hours per battery
Weight	approx. 35 g (without battery)
Dimensions	length: 95 mm, width: 63 mm, height: 35 mm
Output voltage	max. 700 mV at 32 Ω

Induction neck loop

AF frequency response	300 Hz 10 kHz
Impedance	47 Ω
Magnetic field strength at the hearing aid	100 mA/m at 1 kHz and 10 mVA
Guarantee	2 years

Manufacturer declarations

CE Declaration of Conformity



This equipment is in compliance with the essential requirements and other relevant provisions of Directive 2006/95/EC. The declaration is available at www.sennheiser.com.

Before putting the device into operation, please observe the respective country-specific regulations!

WEEE Declaration



Your Sennheiser product was developed and manufactured with high quality materials and components which can be recycled and/or reused. This symbol indicates that electrical and electronic equipment must be disposed of separately from normal waste at the end of its operational lifetime.

Please dispose of this product by bringing it to your local collection point or recycling centre for such equipment. This will help to protect the environment in which we all live.

Batteries



The supplied rechargeable batteries can be recycled. Please dispose of rechargeable batteries as special waste or return them to your specialist dealer. In order to protect the environment, only dispose of exhausted batteries.

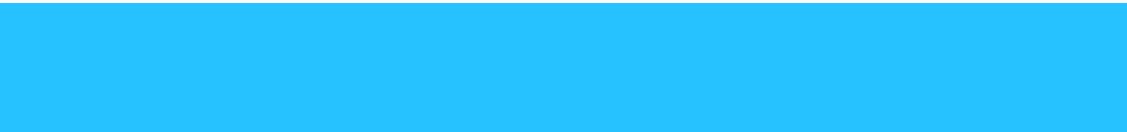

Sennheiser electronic GmbH & Co. KG
30900 Wedemark, Germany
Phone +49 (5130) 600 0
Fax +49 (5130) 600 300
www.sennheiser.com
Printed in Germany

Publ. 04/07

088096/A04